

# Installation and operating manual

## **POOL** - *Master 230 digital*

CE

### **Filter control 230V**

Item No.3100011248

#### **Function**

The **tsi** Pool-Master-230-digital filter control unit allows time-dependent switching on and off of a 230 V alternating current filter pump in accordance with a freely-programmable switching program.

Heating of the swimming pool is controlled by the electronic temperature regulation system while the filter pump is running. The heater is automatically switched off by the internal interlock during filter pauses. The required swimming pool water temperature can be selected on the front panel, or the heater can be switched off. A floating contact (terminals H-H) is available for connecting the heating.

Extra terminals enable the connection of additional devices such as a dosing system. Terminals D-D are floating, and can therefore be used individually. The relay contact between terminals D-D remains closed during the filter periods, the relay contact is opened outside these periods. This contact can be loaded with a voltage of maximum 230 V and a current of maximum 4 A.

Operation of filter pump and heater is displayed by indicator lamps in the front panel, which means that checks can be made at any time.

#### **Specifications**

Dimensions:	220mm x 219mm x 100mm
Operating voltage:	230V/50Hz
Control system power consumption:	abt.10VA
Switching capacity:	Pump: max. 1,0 kW (AC3)
	Heater: max. 230V/400W
	Dosing system: max. 230V/400W
Protection class:	IP 40

#### **Installation**

The controller must be mounted protected against moisture in accordance with its protection class. The device must be powered via a multi-pole main switch with a contact opening width of at least 3mm and a residual current circuit breaker with  $I_{FN} \leq 30\text{mA}$ . **The device must be isolated before opening the housing.**

## Electrical power supply

Electrical power supply connections, in addition to alignment and service work, may only be carried out by approved electricians. The attached circuit diagrams and all applicable safety regulations must be observed.

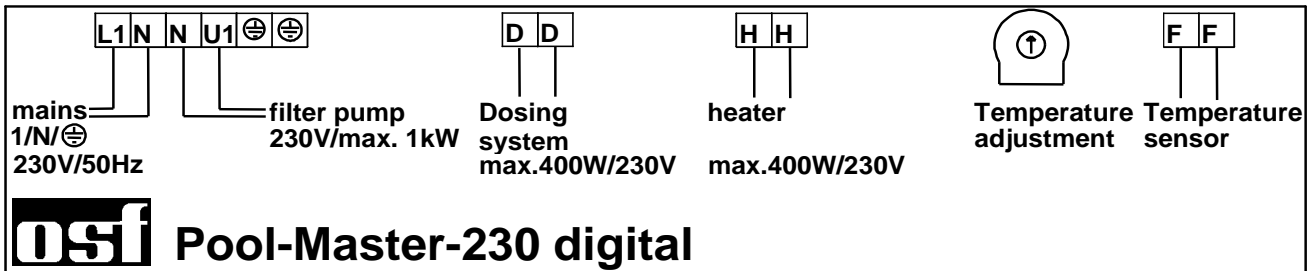

### Heater connection

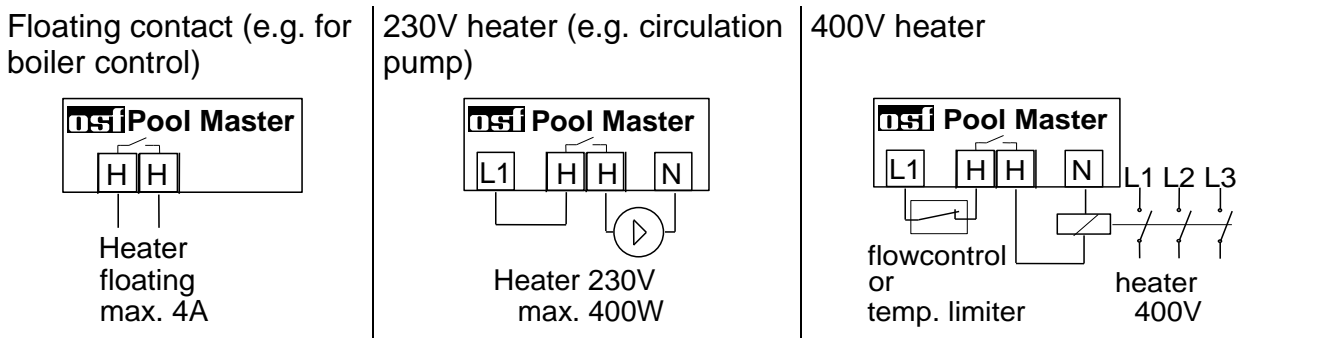

The floating relay contact between terminals 22 and 23 can be loaded with a voltage of maximum 230 V and a current of maximum 4 A.

If the heater requires 400V, an external contactor has to be used.

A flowcontrol switch or a temperature limiter can be inserted between terminals L1 and H to avoid overheating.

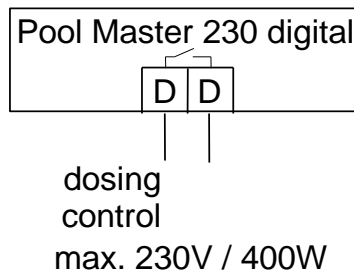

There is a floating relay contact between terminals D-D. This can, for example, be used for activation of the dosing system (the contact remains closed during filter operation).

This contact can be loaded with a maximum of 230 V/4A.

### Temperature sensor



The swimming pool temperature sensor is connected to terminals F-F. The temperature sensor is supplied with a cable length of 1.5 m as standard. If required, this can be

lengthened to maximum 20 m (cross-section minimum 0.5 mm<sup>2</sup>) with a 2-core cable. You should avoid routing the sensor cable near power cables to prevent possible interference. Since precise temperature control can only be achieved with good heat transfer between temperature sensor and swimming pool water, an **ISI** immersion sleeve R ½" (Art. No. 3200200003) should be built into the piping system.

## Front panel displays and controls

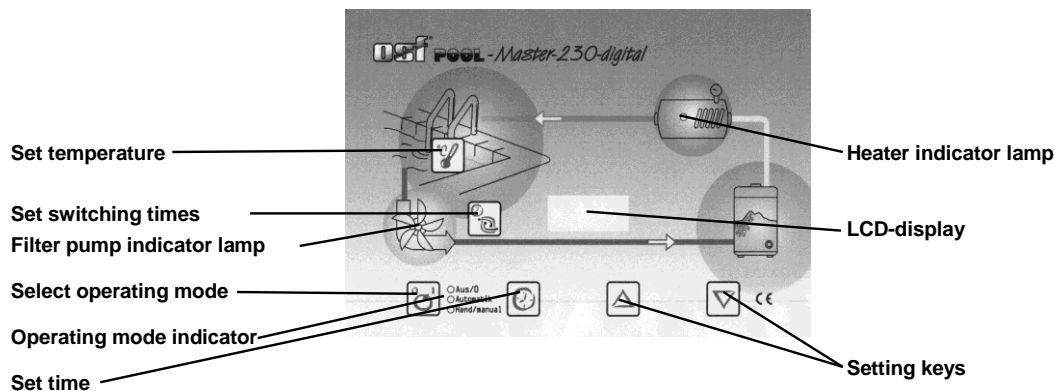

### LCD-display

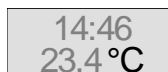

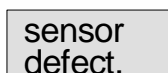

Normal operating display with current water temperature and time.

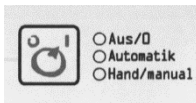

The temperature regulation is not working because the temperature sensor is faulty or not connected.

### Selecting operating mode



The control system can be switched off or you can select between manual and automatic operating mode using the  key. **Caution!** This does not mean that the control system has been switched to voltage-free! The operating mode selected is displayed using the indicator lamps next to the  key.

### Pump indicator lamp

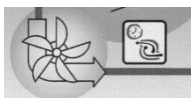

This indicator lamp displays filter pump operation.

### Heater indicator lamp

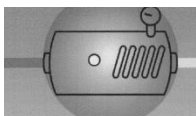





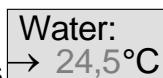

This indicator lamp displays heater operation.

### Selecting the temperature



Use the  key to select the swimming pool water temperature.









1. Press the  key ⇒ the display shows  24,5 °C
2. Use the  and  keys to set the required temperature between 0 °C and 40 °C.
3. Press the  key again to save the required temperature. If no key is pressed for more than 10 seconds during temperature setting, the last temperature selected is saved automatically and the normal operating display will be shown again.

## Setting the time

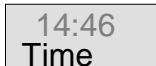

Use the  key to set the current time:

14:46  
Time







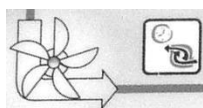



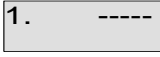

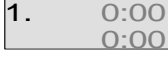





1. Press the  key ⇒ the display shows , the minute display blinks.
2. You can now use the  and  keys to set the minutes.
3. Press the  key ⇒ the hour display blinks.
4. You can now use the  and  keys to set the hours.

Press the  key again to save the time.



## Programming the timer



Use the  key to program the built-in timer, whereby the switch-on time and the associated switch-off time must always be entered as pairs.

1. Press the  key ⇒ the display shows , if no switching time has yet been programmed.
2. If you press one of the  or  keys, or if a switching time has already been programmed, the display shows , the minute display of the top time (switch-on time) blinks. Note: if you press the  key, the current time will be taken over.
3. You can now use the  and  keys to set the required switch-on time minutes.
4. Press the  key again ⇒ the hours in the switch-on time blink
5. You can now use the  and  keys to set the required switch-on time hours.
6. Press the  key again ⇒ the minutes in the switch-off time blink
7. You can now use the  and  keys to set the required switch-off time minutes. Note: if you press the  key, the current time can be taken over, if you press the  and  keys simultaneously the switch-on time set previously will be taken over.
8. Press the  key again ⇒ the hours in the switch-off time blink
9. You can now use the  and  keys to set the required switch-off time hours.
10. Further switching times can now be programmed as in points 1-9.
11. Press the  key again to save the switching time.

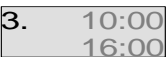
If switching times have already been programmed, you can use the  key to delete them.

1. Press the  key as often as required until the switching time to be deleted is displayed 
2. The switching time is deleted if you press the  and  keys simultaneously.

## **Balancing the temperature controller**

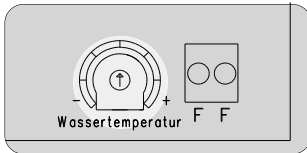

The electronic temperature regulator and the temperature centre are balanced with one another in the works. If one of the sensors is replaced, or if a sensor cable is extended, a new balance must be carried out if necessary using the potentiometers in the controller. Turning the water temperature sensor potentiometer clockwise causes an increase in the water temperature displayed.

## **Fuses**

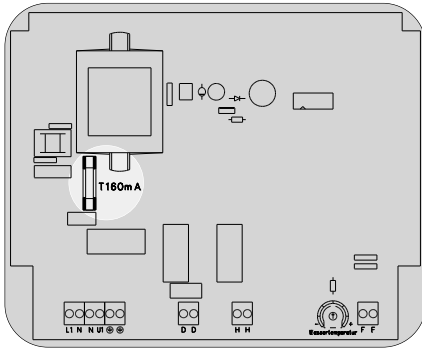

The electronic control system is protected by a 0.16A fine-wire fuse on the PCB in the inside of the device. The short-circuit protection for the filter pump must be provided by a backup fuse of maximum 16A on site.

## Service terminal

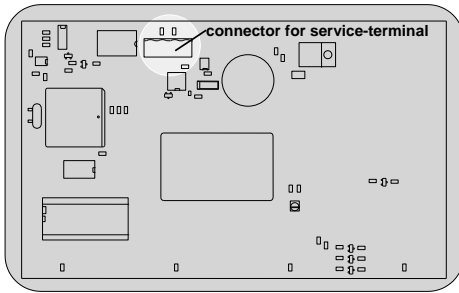

An osf service terminal (Art. No. 3010000900) can be connected to this control system for optimum control system settings for a wide range of swimming pool equipment and for assisting in initial startup and fault diagnosis. The socket for this is located on the PCB inside the device. **Before opening the housing and plugging in the service terminal, you must ensure that the control system has been isolated from the mains!** Once the control system has been switched on, the service terminal display shows the first 4 lines of the diagnosis text, e.g.:

### Filter operation

Temp. reached

Water: 23,0°



Min heating: 120s

Filter unit operation mode

Heater operation mode

Measured water temperature



Min time for heater

Further lines can be called up using the  and  keys. Values in the **top** line can be changed by pressing the  key if necessary.

### Filter unit operating mode

This line displays the current filter unit operating mode.

The following displays are possible:

<i>Control system off</i>	Use the  key to switch the control system off.
<i>Filter unit off</i>	The filter unit is switched off.
<i>Filter operation</i>	The filter unit is switched on using the timer or the  key on the front cover.

### Heater operating mode

This line displays the current temperature regulation operating mode.

The following displays are possible:

<i>heater off</i>	The heater is switched off outside the filter times.
<i>Temp. reached</i>	The heater is switched off because the set temperature has been reached.
<i>Add. heater on</i>	The heater is switched on because the water temperature is below the set temperature.

### Water temperature

The current water temperature is displayed in this line. If the display does not agree with the actual temperature, it can be readjusted using the adjuster on the printed circuit board (see temperature regulation section). Turn the adjuster in a clockwise direction to increase the displayed value. "Sensor break" will be displayed if the temperature sensor is defective.



### Heater minimum time

This line displays the minimum switching on or off durations for the heater by the temperature regulation to avoid too short switching periods. This value can be

adjusted to meet the requirements of the relevant heater equipment if it is displayed in the **top** line:

1. Once the  key has been pressed, the filter unit is switched off and the display shows the following:

<b>Min.heating: 120 s</b> <b>Minimum</b> <b>heater switch</b> <b>on time</b>
---

2. Use the  and  keys to change the minimum time in stages of 10s. The smallest adjustable value is 10s, the largest 1800s
3. If you press the  key again, the normal diagnosis display appears and the filter unit continues to operate. The adjusted value will be saved automatically.

The time set here only influences the temperature regulator behaviour. If the filter pump is switched off, the heater is switched off without delays irrespective of the holding time set. A minimum duration of 2 minutes is set at the works.

### Pump operation time

This line displays the total operating hours for the filter pump.

### Heater operating time

This line displays the total operating hours for the heater.



The following lines enable the service technician to carry out an examination of the filter control unit output relays.

### Filter pump

When the filter pump operating status is displayed in the **top** line of the service terminal, the pump can be switched on or off manually.

1. Once the  key has been pressed, the filter unit is switched off and the the following is displayed:

<b>Filter pump: OFF</b> <b>Pump can be</b> <b>manually</b> <b>switched!</b>
--



2. Use the  key to switch the filter pump on, and the  key to switch it off.
3. If you press the  key again, the normal diagnosis display appears and the filter unit continues to operate.

### Heater

When the heater operating status is displayed in the **top** line of the service terminal, it can be switched on or off manually.

1. Once the  key has been pressed, the filter unit is switched off and the the following is displayed:

<b>Heater</b> <b>MANUAL OPERATION</b> <b>Heater: OFF</b> <b>Filter pump: OFF</b>
---



2. Use the  key to switch the heater on, and the  key to switch it off. The filter pump is automatically switched on as well.
3. If you press the  key again, the normal diagnosis display appears and the filter unit continues to operate.

## Dosing unit

When the dosing unit operating status is displayed in the **top** line of the service terminal, it can be switched on or off manually.

1. Once the  key has been pressed, the filter unit is switched off and the display shows the following:

Dosing unit:	OFF
Filter pump:	OFF

2. Use the  key to switch the dosing unit on, and the  key to switch it off. The filter pump is automatically switched on as well.
3. If you press the  key again, the normal diagnosis display appears and the filter unit continues to operate.

*We hope you have a lot of enjoyment and relaxation in your swimming pool*

Further information can be found on the Internet at the following address:

<https://osf.de/download/documents/documents.php?device=PM-230-digital&subdir=non>

